



# RTD PT100 Interface

Single Channel 3 / 4- Wire PT00 SDI-12 and RS485 Interface Card



Last Updated May 30 2023

OEM Customised Product

**Part Number : NP-1-PT100-24-SD485**

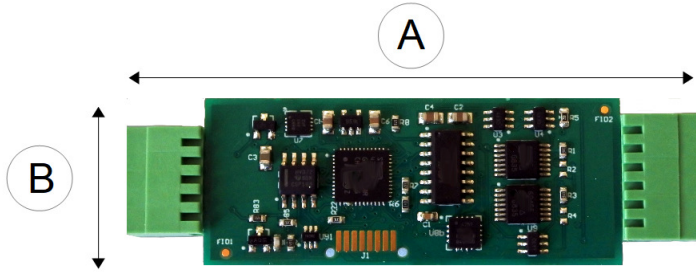

Dimensions A = Length 75 mm B = 24 mm

Figure 1

The is an intelligent general purpose PT100 RTD (Resistive Temperature Device) interface card suitable for connection to data logger or PC, using the simple SDI-12 or RS485 network. Pt100 has a resistance of 100 Ohms at 0 Degrees Celsius.

The card has a combined SDI-12 and RS485 communication port. The choice of which communications port is active depends purely upon how the card is connected to a network. The device automatically detects the network traffic upon which it is connected and will respond only on that network.

The NP-1-PT100-24-SD485 is pre-configured to supply results in Degrees C only. Any change in units has been undertaken by the data logger or PC software. The card has been designed for precision temperature measurements and can compensate for sensor lead resistance. Sensors that meet the IEC 60751-2008 standard can be used. Both 3 and 4 Wire sensor installations compensate for sensor cables.

## OEM Applications

The NP-1-PT100-24-SD485 PCB can be supplied customised for third party applications. Contact Keynes Controls for more details.

### Sensor Port View looking into the Port

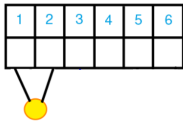

Fig 2

#### Pin-out Sensor Input Port

- 1 Sensor Gnd
- 2 Therm
- 3 -EX RTD (Lead 2)
- 4 IN- RTD- (Lead 1)
- 5 IN+ Not Used
- 6 +EX RTD+ (Lead 1)

### Network Port View looking into the Port

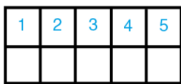

Fig 3

#### Pin-out Sensor Input Port

- 1 Gnd
- 2 +12
- 3 RS485 -
- 4 RS485 +
- 5 SDI-12

## Temperature Measurement

The card supports most of the available thermocouple types. The simplest way to adjust the thermocouple type is in the device setup using the Q-LOG software.

The NP-1-PT100-24-SD485 card is ideally suited to sensors supplied with termination tails.

The advantages of platinum resistance thermometers include:

- High accuracy
- Low drift
- Wide operating range
- Suitability for precision applications.

## Features

- 1 x PT100 - 3 and 4 Wire Interface
- SDI-12 and RS485 Digital Communications Port
- Extended SDI-12 / 485 Address Support: 0-9 , a-z
- 24 Bit ADC Analogue Input
- Low Power - Minimised self heating effect
- Engineering Measurements Deg C
- Free Applications Software - Q-LOG Software
- 2.5 mm Pluggable Terminal Block Connection

The card supports both 3 Wire and 4 Wire sensor configuration and can automatically compensate for the sensor lead resistances.

No special installation tools or plugs are required simply since all signal and sensor cables simply push into the cable clamps mounted on the front and back of the unit.

## Installation

Connect the PT100 sensor into the sensor port as shown in Figure 2. All of the sensor and network cables are terminated into the pluggable terminal blocks that clip onto the sensor ports.

Strip the 5 mm of insulation from the wire. Using a small tipped screwdriver push in the orange tab on the connector. Push the striped wire into the terminal block and release the orange tab. The cable will now be terminated.

## Free Applications Software

The card is supplied with the Q-LOG application software. Q-LOG can be used for Configuration changes, Test Measurement and Data Recording.

The Q-LOG software can be downloaded at:  
[http://keynes-controls.com/Download/QLogSetup50\\_21may2020.zip](http://keynes-controls.com/Download/QLogSetup50_21may2020.zip)

Image is for marketing purposes only The supplied card may differ slightly from the image below.

A = Network Port B = Communication Port

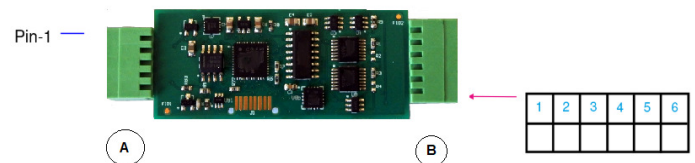
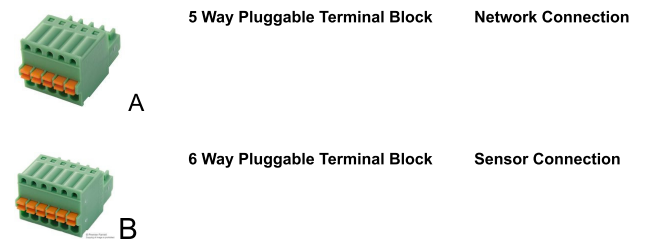

Figure 4

## Cable Entry - Fast Connection

The NP-1-PT100-24-SD485 card uses the 2.5 mm pluggable terminal blocks to connect the sensor and network signals to the card.





# RTD PT100 Interface

Single Channel 3 / 4- Wire PT00 SDI-12 and RS485 Interface Card



## Digital Network

Figure A below demonstrates how to connect multiple NP-1-PT100-24-SD485 cards on a SDI-12 digital network. Each card must have a unique ID number assigned (Address) in order to operate correctly. The SDI-12 network uses a simple three wire low speed application

Multiple Device SDI-12 Network Connection - Figure 5

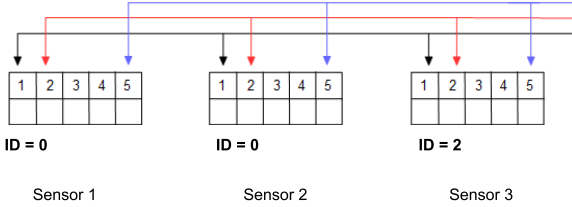

Multiple Device RS485 Network Connection - Figure 6

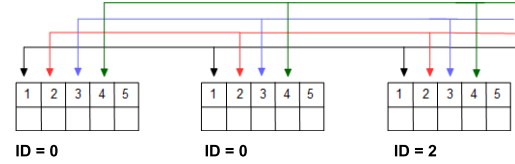

## Cold Junction Compensation

The NP-1-PT100-24-SD485 sensor does not zero correct the bridge and assumes the User will correct the error in post processing of the data. Mean value correction of the measurements is used for bridge zero correction.

## RS-485 Network

The NP-1-PT100-24-SD485 card supports RS-485 network operations. This network type allows for the cards to be widely distributed on a network. The card supports enhanced addressing.

## Commands

### Thermistor Calibration Factor Commands

For the temperature:

- aXT1T0** - thermistor ref temperature (default 25 celcius)
- aXT1R0** - resistance reference (default 3000)
- aXT1ST0** - thermistor 'A' factor
- aXT1ST1** - thermistor 'B' factor
- aXT1ST2** - thermistor 'C' factor
- aXT1ST3** - thermistor 'D' factor

The thermistor calibration factor commands can be used to install additional CJC temperature sensors.

**0M!** - Start Measurement

**0D0!** - Retrieve SI Results  
Temp Chan-0, Temp Chan-1, CJC Temp

**0D1!** (Raw Data)

mV Input Chan-0, mV Input Chan-1, mV adjusted Chan-0, mV Adjusted, mV Adjusted Chab-1

### Communication Port Settings

#### SDI12 Communications

1200 B, 7 Data, N Parity, 1 Stop

#### RS-485 Communications

1200 B, 7 Data, Even Parity, 1 Stop

## 3 Wire RTD Sensor Measurements

Platinum resistance thermometers (PRTs) offer excellent accuracy over a wide temperature range (from -200 to +850 °C). Standard sensors are available from many manufacturers with various accuracy specifications and numerous packaging options to suit most applications.



Sensor Probe

The NP-1-PT100-24-SD485 card uses the three wire sensor configuration and as such provides a compensation loop that can be used to subtract the lead wire resistance from the resistance measurement of the element loop, resulting in a value for just the element resistance. achieving an accurate measurement with this method is predicated on the resistance of each of the leads being exactly equal. When the lead resistances are different, then a small error may occur.

Sensor manufacturers offer a wide range of products that comply with BS1904 class B (DIN 43760): these sensors offer an accuracy of ±0.3 °C at 0 °C. For increased accuracy, BS1904 class A (±0.15 °C) or tenth-DIN sensors (±0.03 °C).

The CJC sensor does not have to be fitted for Pt100 type Sensors.

## Sensor Connection

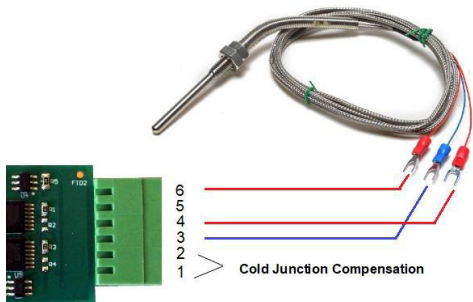
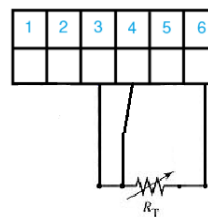

Figure 7 - IEC 60751-2008 PT100 RTD Sensor

Industry Standard 3 Wire Sensor Connection Colour Code

**3 = Red**    **4 = Red**    **6 = White**

## 3 Wire Connection



## 4 Wire Connection

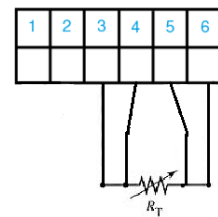

where  $R_T$  = Pt100 Temperature Sensor

Command: **aM!** – start measurement    **aD0!** – display temperature

## Sensor Installation

The CJC thermistor has to be fitted onto pins 1 and 2 before any temperature measurements can be made. Connect the thermocouples to pins 2-3 for Channel-0 and pins 4-5 for Channel-1.

## Technical Specifications

Specifications are accurate at the time of publishing but can be changed without notice.

<b>Power Supply</b>	10 -18 V
<b>Current</b>	2 mA at acquisition 10 uA standby
<b>Input Range</b>	+/- 70 mV Other ranges on request
<b>SDI-12 Port</b>	1 x Port Version 1.03
<b>RS485</b>	1 x Port
<b>Maximum Sample Rate</b>	1 sec - Device dependant
<b>Cable Clamp Size</b>	2.5 mm diameter
<b>Cold Junction Compensation</b>	Fitted Thermistor
<b>Raw Value</b>	Raw data mV/V
<b>Engineering Value</b>	Deg C
<b>Range</b>	Depends sensor installed
<b>Temp Sensor Type</b>	Pt100
<b>CJC - Thermistor Type</b>	3 K EC95 F type material 10K3A1 Betatherm
<b>Calibration</b>	Steinhart-Hart Set at manufacture
<b>Accuracy (CJC)</b>	0.05 Deg -8 to 25 Deg C
<b>Range</b>	-30 to + 60 Deg
<b>Units</b>	Deg C
<b>RMS Noise (Typical values)</b>	less than 1 uV/V (Typical) less than 0.01 Deg C
<b>PCB Dimension</b>	
<b>Length</b>	75 mm
<b>Width</b>	24 mm
<b>Max depth</b>	10 mm
<b>Cable Entry</b>	2.5 mm
<b>Number Therm Channels</b>	2
<b>Measurement Resolution</b>	Depends on sensor type
<b>Sensor Accuracy</b>	Limited to the installed thermocouple 0.1 Deg C Typical.
<b>ADC</b>	24 Bit

## Connection to the USB-SDI12-Pro Media Converter

The image below shows how to connect the NP-1-PT100-24-SD485 card to a SDI-12 media converter. The diagram shows the card connected to the USB-SDI12-Pro device. The card can be connected to any similar device and is not restricted to Keynes manufactured media converters..

The USB-SDI12-Pro can power the interface card directly from the PC USB port without the requirement of an external power supply. This makes testing and configuration operations easy to undertake. A power indicator on the media converter illuminates so long as the USB port in use is operating to specification.

Figure 8

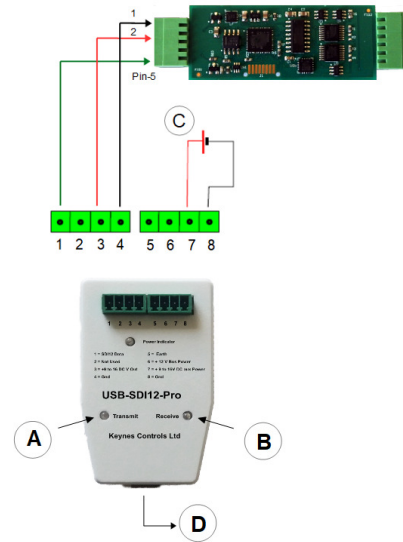

USB-SDI12-Pro	Pin	Card Network Port	Pin
SDI-12 Data	1	Gnd / Ov	1
Not Used	2	+12 V	2
+12 V DC	3		3
Gnd / Ov	4		4
	5	SDI-12 Data	5

## Q-LOG Results

The Q-LOG software stores results into a text file using cell locations exactly like a spreadsheet. The result file uses a CSV (Comma Separated Variable) format making them easy to import into many third party analysis packages.

The card returns the temperature measurement in units of Degrees Celsius

A = Transmit Status LED  
B = Data Status LED  
C = External Power Supply Port.  
D = USB Type B Port

## Keynes Media Converter Observation

Once the **aim!** measurement command is issued then the 'Transmit' LED Status will illuminate. Upon completion of a measurement then the card sends the temperature measurements back across the network and the 'Data' Status LED will illuminate.

## Configuration

The NP-1-PT100-24-SD485 interface is factory preset to operate with 3 K Ohm thermistor The following command can be used to test the NP-1-PT100-24-SD485 sensor. See Figure 15.

Start measurement: **0M!** returns 012 - 1 sec response 1 value  
**0D0!** returns 0+ Deg Celsius

## Youtube Demo Video - Device Configuration in Q-LOG

<https://youtu.be/KEB3WZFfDX4>

## Application Software QLOG The Free Data Display and Configuration Software

The Q-LOG software can be used to make test measurements, configuration changes and display results and is free to download.



# RTD PT100 Interface

Single Channel 3 / 4- Wire PT00 SDI-12 and RS485 Interface Card

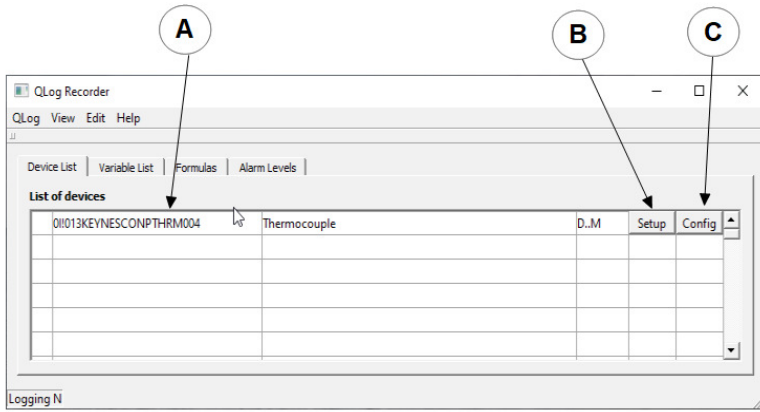
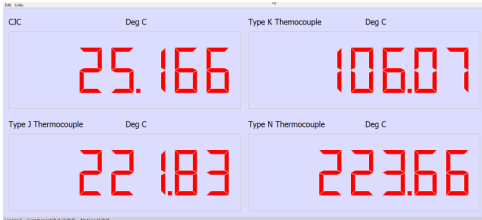

Figure 9

## Real-time Display

Real-time measurements can be displayed to a selection of panel meters and charts that are available in the Q-LOG software.



Use 'View' Tab from the main menu to select the Panel Meter display options.

## Results File

Q-LOG stores measurement values in Comma Separated Variable text format enabling information to be easily imported into spreadsheet and data analysis packages.

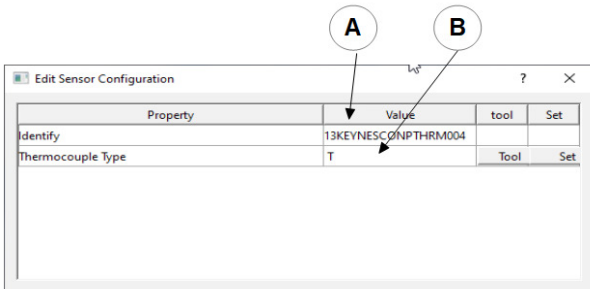

## Simple Measurements & Configuration

The USB media converter powers the NP-1-PT100-24-SD485 card directly across the network and does not require any external supply. Once the sensors are fitted to the card, then it can be configured using the Q-LOG software. Test measurements can be observed as a series of panel meters.

Further details for configuring a media converter for use with Q-LOG can be seen at:

<https://youtu.be/Brjg9K8qaQ>

The Youtube Video demonstrates the Keynes Controls USB media converter in operation.

<https://youtu.be/XuMptEUERwc>

**A = Identifier String**      **B = Setup Button**  
**C = Configure Button**

Q-LOG is the free issue applications software supplied with this product. The software is used to Configure, make test measurements and display data.

1. Ensure the card is connected to a suitable media converter.
2. Set the COMM port used by the media converter into Q-LOG. Use the 'Config' Window.
3. Scan the network and identify the card.

Select the 'Device **Setup**' tab to select the card type. The Window shown in Figure 9 will appear.

Select the '**Config Tab**' and the Sensor Configuration Window shown in Figure 9 will appear

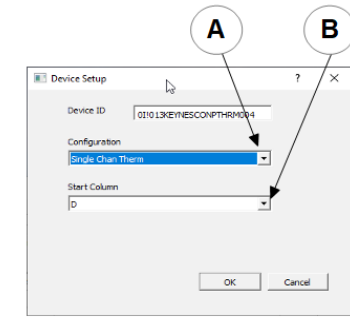

Figure 10

The 'Device Setup' Window is used to

1. Assign the start location for the measurements in the results file. Figure B shows Cell D as the first location for the storage of values in the text results file.
2. The '**Configuration**' list gives the operations supported by the card. Currently this is limited to '**Strain**'.

Q-LOG Device Configuration Window

Figure C shows the 'Sensor Configuration' Window.

**A = Scale and Offset - Output in engineering units.**  
**B = Temperature Sensor Calibration Factors.**

Press 'Set tab' to store a new parameter into the card .

## Optional Accessories

USB-SDI12-Pro	Isolated SDI-12 Media Converter
USB-485-Pro	Isolated RS485 Media Converter