



VibWire-301

Single Channel Vibrating Wire Sensor Interface

Last Updated Feb 20th 22



Introduction

The VibWire-301 is a general purpose, DIN rail mounted single channel vibrating wire sensor interface that can be used in a wide range of applications. The VW-301 can be directly connected to any third party data logger or acquisition system supporting SDI-12, RS-485 and Modbus digital communications, as well as analogue measurement capabilities. The device also supports 4-20 mA current loop operations.

The VibWire-301 uses the Keynes Controls auto-resonance Sensor Excitation technique, therefore no prior knowledge of the sensor operating characteristics is required. The device can be directly connected into many third party SCADA systems using the 4-20 mA current loop and Modbus operations..

Easy Use

The VibWire-301 is the latest in a range of Keynes Control vibrating wire sensor interfaces. The device has been designed from the outset for accuracy of measurement, ease of use, flexible use of communication systems.

The Auto-resonance sensor excitation ensures that no prior vibrating wire sensor operating characteristics need be known in advance, and the minimum wear for sensors.

Network Interfaces

The VibWire-301 supports SDI-12, RS-485, Analogue output (0-2 V DC), and 4-20 mA current loop operations in the same unit. The 4-20mA current loop output is supplied for both the frequency and temperature sensor signals

DIN Rail Installation

The VibWire-301 is installed into enclosures using industry standard DIN rail. A clip on the bottom of the unit secures the device to the rail. A DIN rail mounted device enables fast installation, and replacement as necessary.

PC Based Data Acquisition

The VibWire-301 is fully integrated into the free Keynes Controls Q-LOG Data Acquisition and Display Software enabling the device to be used as a component part within a PC based Vibrating Wire sensor data acquisition system. The software can be used to configure, display and record measurements across a network.



VibWire-301 in a PC Data Acquisition System

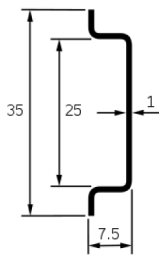
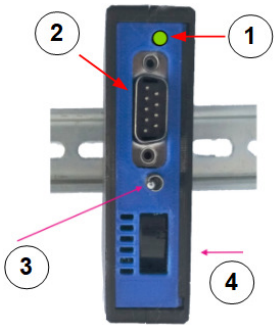

Top Hat rail IEC/EN 60715

- 1. LED Status Indicator
- 2. RS232 Terminal Port
- 3. Speaker Switch
- 4. Speaker



- 1 = 4-20 mA
- 2 = 0-2 V DC
- 3 = SDI-12
- 4 = RS485
- 5 = High Speed RS485

The Status LED shows the User at a glance how the device has been configured.

Features

- 1 x 4 Wire Sensor Port
- Isolated Sensor Input Ports - 1000V DC
- Communications: SDI12 / RS485 / 4-20 mA / 0-2V DC / Modbus
- Auto-resonance Sensor Excitation
- 400Hz to 15 KHz Range
- Full User Configured Outputs - Hz , Digits, SI Units
- Fully Integrated into the Q-LOG Data Acquisition Software
- Supports 2 and 4 Wire Sensors
- Analogue Output 0 to 2 V DC Frequency and Temperature
- Current Loop 4 to 20 mA Outputs
- DIN Rail Mounted Device

High Speed Measurements

The VibWire-301 is capable of high speed sensor measurements. The basic model supports as standard 10 readings a second with the measurements stored directly into CSV file format.

Concurrent Measurements

The VibWire-301 is capable of simultaneous sampling operations for units on a network. The device supports the 'Concurrent' C! Command.

Q-LOG Windows PC Data Acquisition & Display Software

A complete version of Q-LOG without any restrictions can be download from http://keynes-controls.com/Download/QLogSetup50_21may2020.zip



VibWire-301

Single Channel Vibrating Wire Sensor Interface

Last Updated Feb 20th 22



Technical Specification

Physical Size	Height 120 mm - Width 100 mm - Depth 22 mm
Weight	125 g
Power Supply	8-15 V DC
Communication Ports	1 x RS-485 Slave - 9600 Baud, 8 data, 1 stop, no parity 1200 Baud, 7 data, 1 stop, even parity
	1 x SDI-12 - - 1200 Baud, 7 data, 1 stop, even parity
External Power Supply	8 - 15V DC @ 22 mA
Vibrating Wire Measurements	
Analogue Input	24 Bit Sigma Delta
Sensor Excitation	Auto-resonance - Fully automatic frequency selection
Operating Frequency	400 - 15 KHz
Measurement Resolution	0.01 Hz RMS - 20 to 70 Deg C
Measurement Accuracy	± 0.014% of reading - 20 to 70 Deg C
SI Units	Hz, Digits (Hz ² /1000), Eng Units (Quadratic Cal Factors)
Temperature Measurements	Thermistor Temperature Sensor
Analogue Input	24 Bit Sigma Delta
Analogue Output	0 - 2 V DC / 4-20 mA Temperature and Frequency
Current Loop Isolation	500V DC
Temperature Range	- 50 to 100 Deg C
Measurement Accuracy	± 0.25 % of reading - 20 to 70 Deg C
Output	Temperature - Deg C Frequency (Hz), Digits, SI Units
Temperature Sensor	Steinhart-Hart factors: A B C & D Beta Value - lower performance using Beta
Expansion Options	1..32 - 2 X Wire Frequency or Temperature, 1..16 - 4 Wire vibrating wire sensor inputs
Scan Rate: Dynamic	10 - 20 Samples/ Sec (9600 B RS-485) - 10 Hz Analog Out 2 Sec/Chan - using expansion module 250 ms update
16 x 4 Wire / 32 x 2 Wire	30 Sec, 1 minute.

Optional USB Media Converters

An optional media converter can be used to connect the VibWire-301 to a Windows PC using either the SDI-12 or 485 digital networks.



Part No: USB-485-Pro Isolated RS-485 Media Converter
USB-SDI12-Pro Isolated SDI12 Media Converter

The vibrating wire sensor calibration factors can be assigned using the Q-LOG software in a Windows Environment

Analogue Output Ports / 0-2 V DC / 4-20 mA Loop

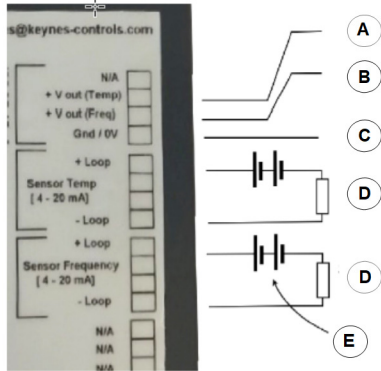

- A = 0-2 V DC (Temperature)
- B = 0-2 V DC Frequency
- C = Gnd / 0V
- D = Loop Sense Resistor
- E = Loop Power Supply

Connection to a Data Logger

The VibWire-301 connects to any third party data logger supporting SDI-12, 485 Communications or directly onto an analogue data acquisition.

Analogue Output Ports -- 0..2 V DC / 4..20 mA Loop

The analogue output ports, regardless of type, can be scaled to represent any measurement value in Hz, Digits and SI units for the frequency components, and Deg C for the temperature signal.

The device has isolated loops for both the frequency and temperature signals..The current loop opto-isolation prevents signal corruption due to ground loops.

Terminal Port Communications Setup

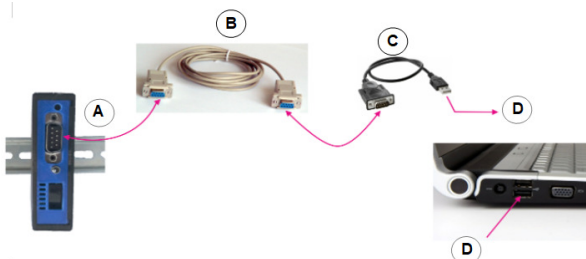

The VibWire-301 can be fully configured using the Terminal Port Menu system built into the device and accessed using the RS-232 Port mounted on the front of the device.

No device drivers are required when configuring the device using the RS232 port

- A = RS232 Terminal Port Connection
- B = Null Modem cable
- C = RS232 to USB Converter
- D = PCB USB Port

SDI-12 1200 = 1200 Baud, 7 , E, 1 Stop
RS485 1200 = 1200 Baud, 7 , E, 1 Stop
RS232 Terminal Port - 9600, 8, N, 1, STOP



VibWire-301

Single Channel Vibrating Wire Sensor Interface

Last Updated Feb 20th 22



Q-LOG Data Acquisition, Configuration and Display Software

Q-Log is the Keynes Controls Data Recording and Display software and has been designed solely for use with intelligent sensors and interfaces. The software operates as a stand-alone package and requires the use of an SDI-12, or RS-485 media converter. Q-LOG enables PC based systems to be created and tested. The software is free issued with the Keynes Controls instrumentation.

Common Keynes Controls device identifier strings.

Product	ID string
VibWire-201-Pro	13KEYNESVWRD0A001
VibWire-101 VW sensor interface	13KEYNESCOVW101A011
VibWire-108 VW sensor interface	13KEYNESCOVW108A016
PIEZO-RM water level sensor	13KEYNESCOBPRESR001
Barom-SDI-12 barometer	13KEYNESCOBPRESR003
I-P-I	13KEYNESCOBPINCL005
AquaDAT sensor interface	13KEYNESCOAQUADAT008
Single channel strain gage	13KEYNESCOSTRAIN027

Q-LOG Devices List Window.

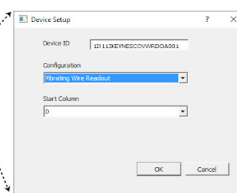
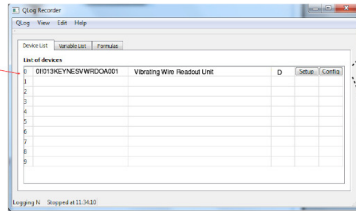
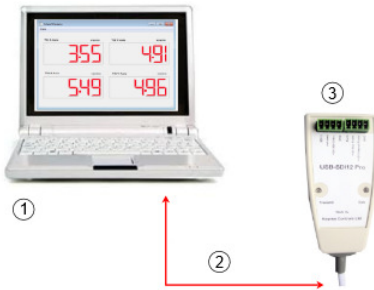

Fig-16

Image opposite demonstrates how the VibWire-301 is identified in Q-LOG. All the devices that are detected on a network are shown here.

Windows PC based Data Acquisition Systems

The simplest Windows PC based vibrating wire sensor solution is shown below. A Windows PC running Q-LOG and an isolated USB media converter.



1. Windows PC running Q-LOG
2. USB Data Link
3. Optional Media Converter

Part Number: USB-SDI12-Pro (SDI12 Network)
USB-485-Pro (RS485 Network)

The Keynes Controls media converters can power the VibWire-301 directly from a laptop / Desktop USB Port without the use of an external power supply.

Configuration

The measurements are recorded into unique time stamped text files that can be read by a spreadsheet. Information is easy to understand and process.

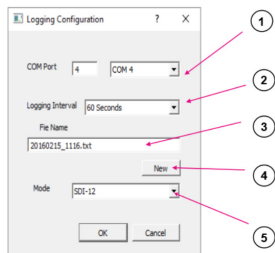

Q-LOG Network Configuration Window

Q-LOG Software Download

The Q-LOG software can be downloaded at:

http://keynes-controls.com/Download/QLogSetup50_21may2020.zip

Youtube: <https://youtu.be/pxOO7UZbX5g>

Q-LOG Data Display

The Q-LOG software can be used to:

1. Display Results in - Hz / Digits / Engineering Units
2. Real-time Charts.
3. User Defined Panel meters

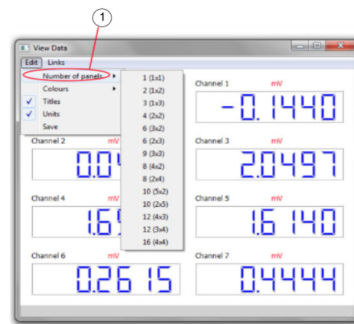

Q-LOG Panel Meter Selection Window

No programming experience is required. The sensor calibration factors can be written directly into the device. Their panel meters can be used to display sensor results.

Youtube Video Title: VW-301 Qlog Basic Operations

See: <https://youtu.be/qWV1D8KPPfc>

Data Acquisition and Testing

The Q-LOG software is an ideal tool for testing measurement systems in the workshop before installation on site, Sensors can be configured, test measurements made, results displayed for easy analysis.

Confidence can be made in the measurements before any installation onto data recorders or site wide monitoring systems.

Configuration Settings

1. Enter Comm Port identified for USB media converter
2. Data Recording Sample Rates
- (1, 5, 10 Secs, 1 to 10 minutes, 1 and 6 Hours)
3. Time stamp Log Filename
4. New Button
- Automatically create a new time stamped log file.
5. Network Type Selection - SDI-12 / RS-485.



VibWire-301



Single Channel Vibrating Wire Sensor Interface

Last Updated Feb 20th 22

SDI-12 / RS-485 Supported Commands

The following commands are supported by the VibWire-301 and are used by data loggers and data acquisition systems. The commands have been included to allow the VibWire-301 to operate easily with third party data loggers that support industry standard SDI-12 command set.

Start Measurement: M0! D0! – is the main command required to start a measurement and return the data to a logger unit or PC data acquisition system.

Description	Master	VibWire-301 Response
Acknowledge active	a!	a!\r\n
Send ID: provided to complement SDI-12 protocol	a!	a13KEYNESVWRDOA001\r\n Part Description assigned by Keynes
Address Query identifies instrument address and commonly used on single instrument operations only.	?!	a!\r\n
Change Address: used to change instrument address from a (initial) to b new ID for network operations	aAb!	Where a = ID number 0 - 9 (standard) / (a..z) Enhanced SDI-12 0 - 9 / a - z for RS485
Start Measurement instruct an instrument to make measurement	a = initial address b = new address aM!	b!\r\n a : b = number 0 - 9 or a - z a0261\r\n ****
Concurrent measurement: Used for starting a measurement for all instruments on a network at the same time.	a = address of instrument example 0M! starts scan for ID 0 aC!	instrument with address a returns 1 x 4 wire reading in 1 second. a0268\r\n initial response only after receipt of instruction and no response when data ready to be sent.
This command frees RS-485 bus for other devices	32 x 2 Wire Measurements aM2! aD0! aD1! aD2! aD3! - 16 x Freq aM3! aD0! aD1! aD2! aD3! - 16 x Freq	+xxxx.x+xxxx.x+xxxx.x+xxxx.x\r\n
MUX-16/342 Expansion Unit	16 x 4 Wire Measurements aM2! aD0! aD1! aD2! aD3! aD4! aD5! aD6! aD7! D0-D4 = Frequency D4-D7 = Temperature VibWire-301 supports 2 thermistor types	
Thermistor 1 & 2	Thermistor Type 1 Temperature sensor settings Parameters from the sensor calibration sheet Steinhart-Hart Parameters Thermistor resistance/temp calculation	Resistance at 25 Deg C T0 - generally 25 Deg C Beta Value
Thermistor Type 2 Temperature sensor settings Parameters from the sensor calibration sheet Steinhart-Hart Parameters Thermistor resistance/temp calculation	aXT1RE! aXT1T0! = 25 aXT1BET! aXT1ST0! aXT1ST1! aXT1ST2! aXT1ST3! aXT2RE! aXT2T0! = 25 aXT2BET! aXT2ST0! aXT2ST1! aXT2ST2! aXT2ST3!	A in Steinhart-Hart B in Steinhart-Hart C in Steinhart-Hart D in Steinhart-Hart Resistance at 25 Deg C T0 - generally 25 Deg C Beta Value A in Steinhart-Hart B in Steinhart-Hart C in Steinhart-Hart D in Steinhart-Hart
VW Sensor Input Channel Settings Sets the process option for frequency calculations	aXCH0FN! F = Frequency type N = VW Channel 0 .. 7	0 = output in Hz 1 = output in digits = F ² /1000 2 = use formula A + B*digits + C*digits ² + D*temperature digits = Frequency ² in units of Hz ²
Thermistor Temperature Calculation	aXT1TYn! a = ID n = integer 0 .. 2	0 = resistance ratio - thermistor data sheet (R _t /R ₂₅) 1 = Beta value calculation 1/T = 1/T ₀ + log(r)/Beta where r = R _t /R ₂₅ 2 = Steinhart-Hart equation 1/T = A + B(Ln R _t /R ₂₅) + C(Ln R _t /R ₂₅) ² + D(Ln R _t /R ₂₅) ³

Sensor Connection

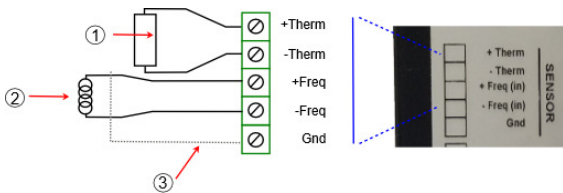

1. Thermistor Temperature Sensor.
2. Vibrating Wire Sensor.- 2 or 4 Wire.
3. Earth / Shield.

Calculations

The VibWire-301 can be configured to convert frequency into engineering units. The common calculation for vibrating wire sensors uses Digits. Keynes Controls defines the Digits calculation as:

$$\text{Digits} = \frac{\text{Frequency}^2}{1000} \frac{(\text{Hz}^2)}{1000}$$

$$\text{SI Units Calculation} \quad X = A + Bd + Cd^2 - D$$

where **d** = measured frequency in Digits.
and **D** = Temperature Correction Coefficient
t = temperature in Deg C

High Speed Measurements - 4-20 mA / 0 - 2 V DC

The VibWire-301 can operate in high speed mode. The simplest way to use the device in high speed mode is to connect it to an analogue data acquisition system via the 0-2 V DC or 4-20 mA loop output ports. The analogue output ports can also be used to drive process display units.

The device has two analogue output signals that can be individually configured to represent the sensor frequency in Hz, Digits or SI Units. The temperature sensor output can be scaled to represent Degree Celsius or mV. High speed vibrating wire measurements

Analogue Output Port Connection

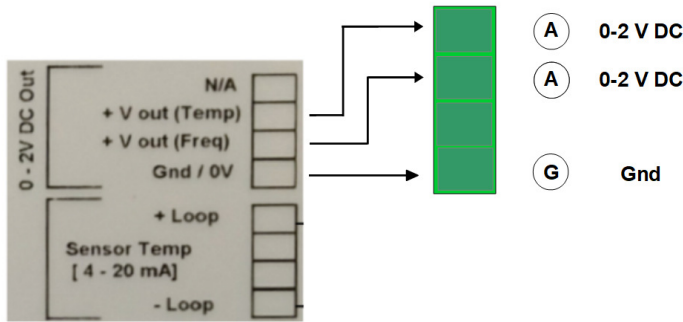

A = Analogue Input 0-2 V DC (Frequency and Temperature signals)
G = Gnd/ 0V

The menu system below are the default settings for a vibrating wire sensor operating over the range 500 - 1300 Hz as used by the Geokon 4200 sensor.

Sensor Setup

1 Frequency proc	Hz
2 Center Frequency (Hz)	900
3 First Ping (us)	5000
4 Cal A	0.
5 Cal B	1.0000
6 Cal C	0.
7 Cal D	0.
8 Stabilization after pluck (us)	5000
9 Sample number of pulses	20

The configuration settings show the output signal from the device will represent a Vibrating Wire signal in Hz.

Current Loop Port 4-20 mA

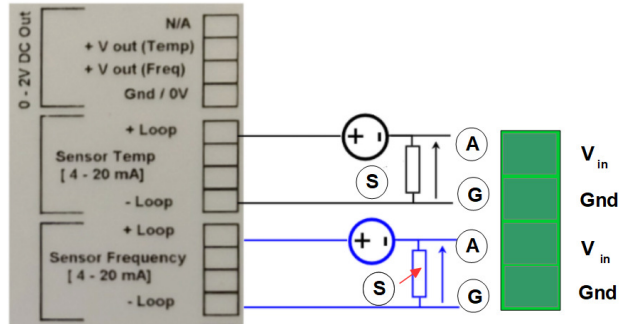

The VibWire-301 supports two individually isolated 4-20 mA loop outputs that can be configured to represent the Frequency and temperature signal components of the sensor. The current loop not only represents the sensor signal but is also powered from it.

A precision 100 Ohm sense resistor is used to convert the loop signal to a voltage that can be measured by an analogue data acquisition system.

The sensor output signal can be configured to represent Hz, Digits or SI units.

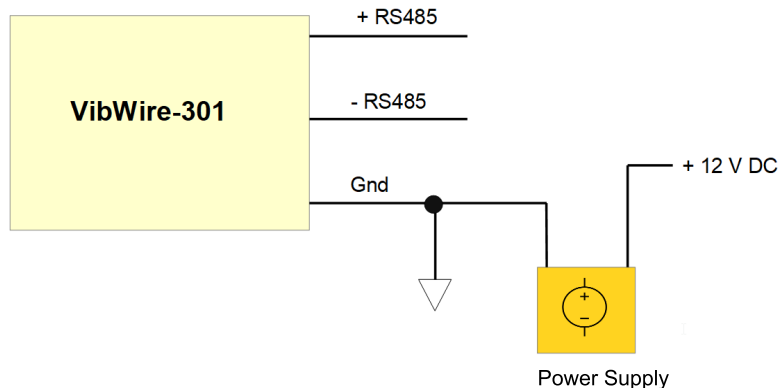

Power Supply / Earth Connection

Connect the VibWire-301 to a power supply as shown in the figure opposite.

The 0V / Gnd connection of the DC power supply connects to the Gnd connection on the VibWire-301

Incorrect power supply connection can stop the VibWire-301 from operating correctly.